



## CHARCOAL GRILL OWNER'S GUIDE

Do not discard. This owner's guide contains important product dangers, warnings, and cautions. For assembly instructions, refer to assembly guide. Do not use grill indoors!

Visit [www.weber.com](http://www.weber.com), select your country of origin, and register your grill today.



EN ZH KO JA TH ID

59689

04/01/18



# SAFETY

**Failure to follow the DANGERS, WARNINGS, and CAUTIONS contained in this Owner's Guide may result in serious bodily injury or death, or may result in a fire or an explosion causing damage to property.**

**Please read all safety information contained in this Owner's Guide before operating this grill.**

## DANGERS

- ⚠ Do not use indoors! This grill is designed for outdoor use in a well-ventilated area and is not intended for and should never be used as a heater. If used indoors, toxic fumes will accumulate and cause serious bodily injury or death.
- ⚠ Do not use in a garage, building, breezeway, or any other enclosed area.
- ⚠ Do not use petrol, alcohol, or other highly volatile fluids to ignite charcoal. If using charcoal starter fluid (not recommended), remove any fluid that may have drained through the bowl vents before lighting the charcoal.
- ⚠ Do not add charcoal starter fluid or charcoal impregnated with charcoal lighter fluid to hot or warm charcoal. Cap starter fluid after use, and place a safe distance away from the grill.
- ⚠ Keep the cooking area clear of flammable vapour and liquids, such as petrol, alcohol, etc., and combustible material.

## WARNINGS

- ⚠ Do not use this grill unless all parts are in place. This grill must be properly assembled according to the assembly instructions. Improper assembly may be dangerous.
- ⚠ Never use grill without the ash catcher installed.
- ⚠ Do not use this grill under any overhead combustible construction.
- ⚠ The use of alcohol, prescription, or non-prescription drugs may impair the consumer's ability to properly assemble or safely operate the grill.
- ⚠ Exercise caution when operating your grill. It will be hot during cooking or cleaning, and should never be left unattended.
- ⚠ WARNING! This barbecue will become very hot, do not move it during operation.
- ⚠ WARNING! Keep children and pets away.
- ⚠ WARNING! Do not use spirit or petrol for lighting or re-lighting! Use only firelighters complying to EN 1860-3!
- ⚠ This grill is not intended to be installed in or on recreational vehicles and/or boats.
- ⚠ Do not use this grill within five feet (1.5 m) of any combustible material. Combustible materials include, but are not limited to, wood or treated wood decks, patios, and porches.
- ⚠ Keep the grill on a secure, level surface at all times, clear of combustible material.
- ⚠ Do not place grill on glass or a combustible surface.
- ⚠ Do not use grill in high winds.
- ⚠ Do not wear clothing with loose flowing sleeves while lighting or using the grill.
- ⚠ Never touch the cooking or charcoal grate, ashes, charcoal, or the grill to see if they are hot.
- ⚠ Extinguish charcoal when finished cooking. To extinguish, close bowl vent and lid damper and place lid on bowl.

- ⚠ Use heat-resistant barbecue mitts or gloves (conforming to EN 407, Contact Heat rating level 2 or greater) while cooking, adjusting air vents (dampers), adding charcoal, and handling thermometer or lid.



- ⚠ Use proper tools, with long, heat-resistant handles.
- ⚠ Always put charcoal on top of the charcoal (lower) grate. Do not put charcoal directly in the bottom of the bowl.
- ⚠ Do not lean on or overload the end of the table.
- ⚠ Do not use the TUCK-AWAY lid holder as a handle to lift or move the grill.
- ⚠ Do not hang the lid on the bowl handle.
- ⚠ Never dump hot charcoal where it might be stepped on or be a fire hazard. Never dump ashes or charcoal before they are fully extinguished.
- ⚠ Do not store grill until ashes and charcoal are fully extinguished.
- ⚠ Do not remove ashes until all charcoal is completely burned out and fully extinguished and grill is cool.
- ⚠ Keep electrical wires and cords away from the hot surfaces of the grill and away from high traffic areas.

⚠ **WARNING!** Do not use the barbecue in a confined and/or habitable space e.g. houses, tents, caravans, motor homes, boats. Danger of carbon monoxide poisoning fatality.

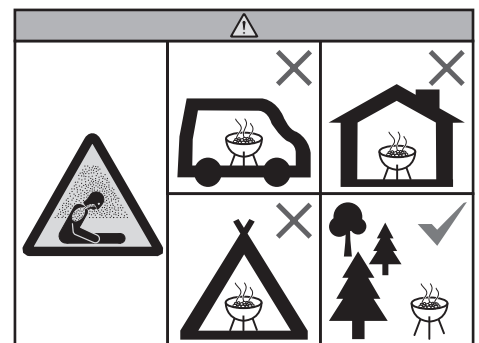

## CAUTIONS

- ⚠ Do not use water to control flare-ups or to extinguish charcoal.
- ⚠ Lining the bowl with aluminum foil will obstruct the air flow. Instead, use a drip pan to catch drippings from meat when cooking using the indirect method.
- ⚠ Grill brushes should be checked for loose bristles and excessive wear on a regular basis. Replace brush if any loose bristles are found on cooking grate or brush. WEBER recommends purchasing a new stainless steel bristle grill brush at the beginning of every spring.



Thank you for purchasing a WEBER product. Weber-Stephen Products LLC, 1415 S. Roselle Road, Palatine, Illinois 60067 ("WEBER") prides itself on delivering a safe, durable, and reliable product.

This is WEBER's Voluntary Warranty provided to you at no extra charge. It contains the information you will need to have your WEBER product repaired in the unlikely event of a failure or defect.

**Pursuant to applicable laws, the customer has several rights in case the product is defective. Those rights include supplementary performance or replacement, abatement of the purchasing price, and compensation. In the European Union, for example, this would be a two-year statutory warranty starting on the date of the handover of the product. These and other statutory rights remain unaffected by this warranty provision. In fact, this warranty grants additional rights to the Owner that are independent from statutory warranty provisions.**

### **WEBER'S VOLUNTARY WARRANTY**

WEBER warrants, to the purchaser of the WEBER product (or in the case of a gift or promotional situation, the person for whom it was purchased as a gift or promotional item), that the WEBER product is free from defects in material and workmanship for the period(s) of time specified below when assembled and operated in accordance with the accompanying Owner's Manual. (Note: If you lose or misplace your WEBER Owner's Manual, a replacement is available online at [www.weber.com](http://www.weber.com), or such country-specific website to which Owner may be redirected.) Under normal, private single family home or apartment use and maintenance, WEBER agrees within the framework of this warranty to repair or replace defective parts within the applicable time periods, limitations, and exclusions listed below. TO THE EXTENT ALLOWABLE BY APPLICABLE LAW, THIS WARRANTY IS EXTENDED ONLY TO THE ORIGINAL PURCHASER AND IS NOT TRANSFERABLE TO SUBSEQUENT OWNERS, EXCEPT IN THE CASE OF GIFTS AND PROMOTIONAL ITEMS AS NOTED ABOVE.

### **OWNER'S RESPONSIBILITIES UNDER THIS WARRANTY**

To ensure trouble-free warranty coverage, it is important (but it is not required) that you register your WEBER product online at [www.weber.com](http://www.weber.com), or such country-specific website to which Owner may be redirected. Please also retain your original sales receipt and/or invoice. Registering your WEBER product confirms your warranty coverage and provides a direct link between you and WEBER in case we need to contact you.

The above warranty only applies if the Owner takes reasonable care of the WEBER product by following all assembly instructions, usage instructions, and preventative maintenance as outlined in the accompanying Owner's Manual, unless the Owner can prove that the defect or failure is independent of non-compliance with the above mentioned obligations. If you live in a coastal area, or have your product located near a pool, maintenance includes regular washing and rinsing of the exterior surfaces as outlined in the accompanying Owner's Manual.

### **WARRANTY HANDLING / EXCLUSION OF WARRANTY**

If you believe that you have a part which is covered by this Warranty, please contact WEBER Customer Service using the contact information on our website ([www.weber.com](http://www.weber.com), or such country-specific website to which Owner may be redirected). WEBER will, upon investigation, repair or replace (at its option) a defective part that is covered by this Warranty. In the event that repair or replacement are not possible, WEBER may choose (at its option) to replace the grill in question with a new grill of equal or greater value. WEBER may ask you to return parts for inspection, shipping charges to be pre-paid.

This WARRANTY lapses if there are damages, deteriorations, discolourations, and/or rust for which WEBER is not responsible caused by:

- Abuse, misuse, alteration, modification, misapplication, vandalism, neglect, improper assembly or installation, and failure to properly perform normal and routine maintenance;
- Insects (such as spiders) and rodents (such as squirrels), including but not limited to damage to burner tubes and/or gas hoses;
- Exposure to salt air and/or chlorine sources such as swimming pools and hot tubs/spas;
- Severe weather conditions such as hail, hurricanes, earthquakes, tsunamis or surges, tornadoes or severe storms.

The use and/or installation of parts on your WEBER product that are not genuine WEBER parts will void this Warranty, and any damages that result hereby are not covered by this Warranty. Any conversion of a gas grill not authorised by WEBER and performed by a WEBER authorised service technician will void this Warranty.

### **PRODUCT WARRANTY PERIODS**

Bowl, lid, and center ring:  
10 years, no rust through/burn through

ONE-TOUCH cleaning system:  
5 years, no rust through/burn through

Plastic components:  
5 years, excluding fading or discolouration

All remaining parts:  
2 years

### **DISCLAIMERS**

APART FROM THE WARRANTY AND DISCLAIMERS AS DESCRIBED IN THIS WARRANTY STATEMENT, THERE ARE EXPLICITLY NO FURTHER WARRANTY OR VOLUNTARY DECLARATIONS OF LIABILITY GIVEN HERE WHICH GO BEYOND THE STATUTORY LIABILITY APPLYING TO WEBER. THE PRESENT WARRANTY STATEMENT ALSO DOES NOT LIMIT OR EXCLUDE SITUATIONS OR CLAIMS WHERE WEBER HAS MANDATORY LIABILITY AS PRESCRIBED BY STATUTE.

NO WARRANTIES SHALL APPLY AFTER THE APPLICABLE PERIODS OF THIS WARRANTY. NO OTHER WARRANTIES GIVEN BY ANY PERSON, INCLUDING A DEALER OR RETAILER, WITH RESPECT TO ANY PRODUCT (SUCH AS ANY "EXTENDED WARRANTIES"), SHALL BIND WEBER. THE EXCLUSIVE REMEDY OF THIS WARRANTY IS REPAIR OR REPLACEMENT OF THE PART OR PRODUCT.

IN NO EVENT UNDER THIS VOLUNTARY WARRANTY SHALL RECOVERY OF ANY KIND BE GREATER THAN THE AMOUNT OF THE PURCHASE PRICE OF THE WEBER PRODUCT SOLD.

YOU ASSUME THE RISK AND LIABILITY FOR LOSS, DAMAGE, OR INJURY TO YOU AND YOUR PROPERTY AND/OR TO OTHERS AND THEIR PROPERTY ARISING OUT OF THE MISUSE OR ABUSE OF THE PRODUCT OR FAILURE TO FOLLOW INSTRUCTIONS PROVIDED BY WEBER IN THE ACCOMPANYING OWNER'S MANUAL.

PARTS AND ACCESSORIES REPLACED UNDER THIS WARRANTY ARE WARRANTED ONLY FOR THE BALANCE OF THE ABOVE MENTIONED ORIGINAL WARRANTY PERIOD(S).

THIS WARRANTY APPLIES TO PRIVATE SINGLE FAMILY HOME OR APARTMENT USE ONLY AND DOES NOT APPLY TO WEBER GRILLS USED IN COMMERCIAL, COMMUNAL OR MULTI-UNIT SETTINGS SUCH AS RESTAURANTS, HOTELS, RESORTS, OR RENTAL PROPERTIES.

WEBER MAY FROM TIME TO TIME CHANGE THE DESIGN OF ITS PRODUCTS. NOTHING CONTAINED IN THIS WARRANTY SHALL BE CONSTRUED AS OBLIGATING WEBER TO INCORPORATE SUCH DESIGN CHANGES INTO PREVIOUSLY MANUFACTURED PRODUCTS, NOR SHALL SUCH CHANGES BE CONSTRUED AS AN ADMISSION THAT PREVIOUS DESIGNS WERE DEFECTIVE.

Refer to International Business Units list at the end of this Owner's Manual for additional contact information.

Visit [www.weber.com](http://www.weber.com), select your country of origin, and register your grill today.



## COOKING SYSTEM

Extensive thought was put into how your charcoal grill was designed. We design our grills to perform so that you never have to worry about flare-ups, hot and cold spots or burnt food. Expect excellent performance, control and results every time.

### Bowl and Lid

Every WEBER charcoal grill is made with a baked-on porcelain-enamel coated steel bowl (A) and lid (B). This is important because it means it will never peel or flake. The reflective surface provides convection cooking, so that the heat radiates round the food much like an indoor oven, providing you with even cooking results.

### Dampers and Vents

A big factor in charcoal grilling is air. The more air you allow into the grill, the hotter the fire will grow (up to a point) and the more often you will need to replenish it. So to minimise replenishing, keep the lid closed as much as possible. The bowl vents (C) on the bottom of the grill should be left open whenever you are grilling, but to slow the rate that your fire burns, close the lid damper(s) (D) as much as halfway.

### Cooking Grate

Made of heavy-duty plated steel, the cooking grate (E) provides ample area to make all your favourite meals.

### Charcoal Grate

The charcoal grate (F) has what it takes to withstand the heat of any charcoal fire. Made of heavy-duty steel, this durable grate will not warp or burn through. In addition, it gives you enough space for direct or indirect cooking, providing you with the flexibility to cook the way you wish.

### Special Features

Your grill may be equipped with the following special feature:

#### TUCK-IN-CARRY Lid-Lock

The TUCK-IN-CARRY (G) lid-lock allows for carrying, and also lowers to double as a lid-holder.

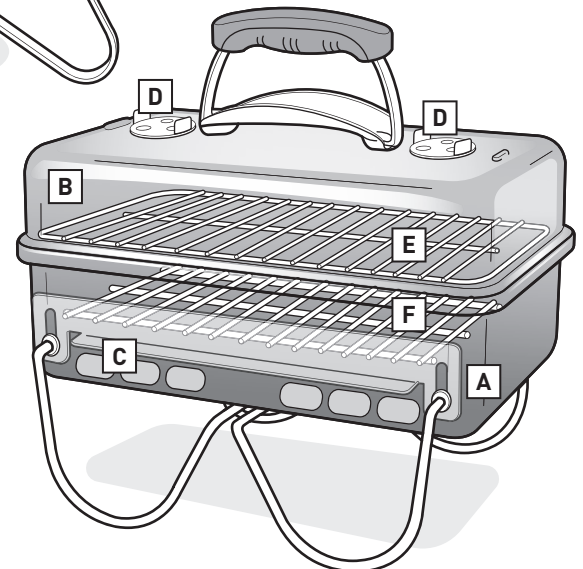
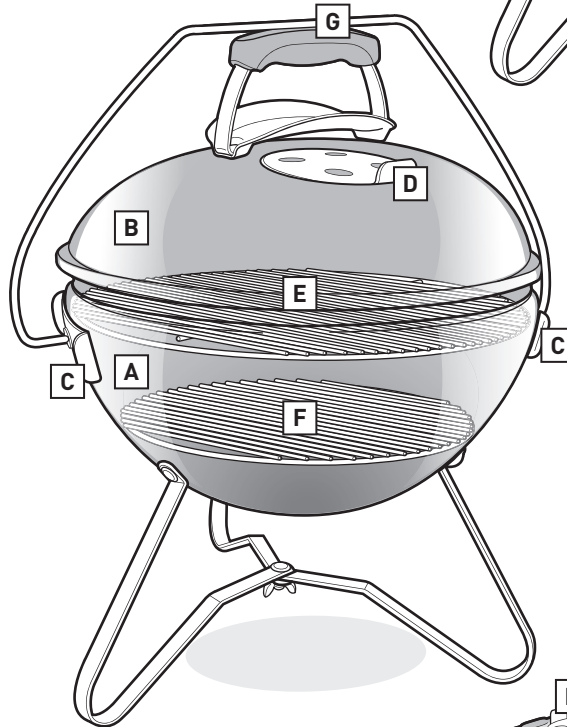
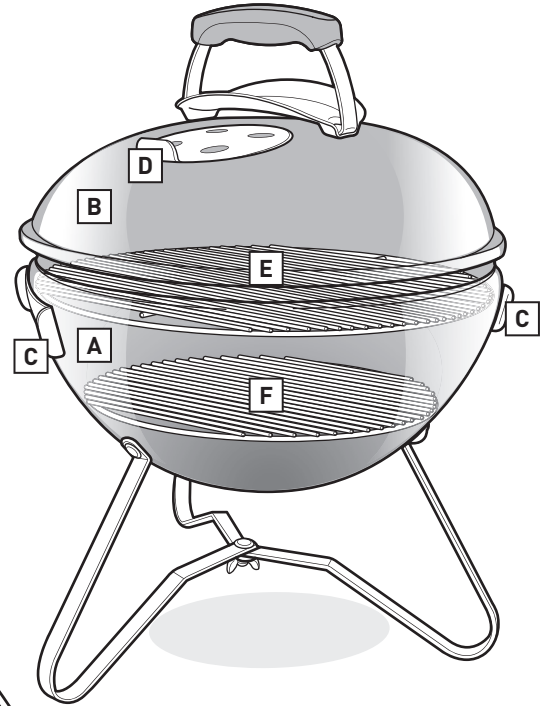



## Choose a Proper Location to Grill

- Only use this grill outdoors in a well-ventilated area. Do not use in a garage, building, breezeway or any other enclosed area.
- Keep the grill on a secure, level surface at all times.
- Do not use grill within 1.5 metres of any combustible material. Combustible materials include, but are not limited to, wood or treated wood decks, patios and porches.

## Choose How Much Charcoal to Use

Choosing charcoal quantity depends on what you are grilling and the size of your grill. If you are grilling small, tender pieces of food that take less than 20 minutes, refer to the *Measuring & Adding Charcoal for Direct Heat* chart. If you are grilling larger joints of meat that require 20 minutes or more grilling time, or delicate foods, refer to the *Measuring & Adding Charcoal for Indirect Heat* chart. Use the charcoal cup supplied with your grill to measure the appropriate amount of charcoal. For more details about the difference between direct and indirect cooking, refer to the **GRILLING METHODS** section.

## The Very First Time You Grill

It is recommended that the grill be heated up and the fuel kept red hot, with the lid on, for at least 30 minutes prior to cooking for the first time.

## Preparing the Grill for Lighting

1. Remove the lid. Depending on your grill model, you may be able to position it on the side of your grill using the TUCK-IN-CARRY lid lock which lowers to double as a lid-holder.
2. Remove the cooking (top) grate from your grill.
3. Remove the charcoal (bottom) grate and clear ashes or chunks of old charcoal from the bottom of the bowl and ash catcher (depending on your model of grill).
4. Open bowl vent(s).
5. Replace charcoal (bottom) grate.

*NOTE: Instructions for using lighter fluid were purposely left out of this owner's guide. Lighter fluid is messy and can transmit a chemical taste to your food, while lighter cubes (sold separately) do not. If you choose to use lighter fluid, follow the manufacturer's instructions and NEVER add lighter fluid to a burning fire.*

## Lighting the Charcoal Using a Chimney Starter

The simplest, most thorough way to light any kind of charcoal is to use a chimney starter; particularly, the RAPIDFIRE chimney starter (sold separately). Refer to the cautions and warnings included with the RAPIDFIRE chimney starter before lighting.

1. Put a few sheets of wadded up newspaper in the bottom of the chimney starter and set the chimney starter on the charcoal grate (A); or put a few lighter cubes in the centre of the charcoal grate and place the chimney starter over them (B).

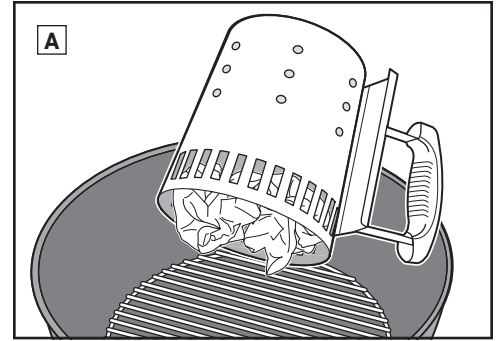

2. Fill the chimney starter with charcoal (C).
3. Light the lighter cubes or newspaper through the holes on the side of the chimney starter (D).
4. Keep the chimney starter in place until the charcoal is fully lit. You can tell when the charcoal is fully lit when it is covered with a coating of white ash.

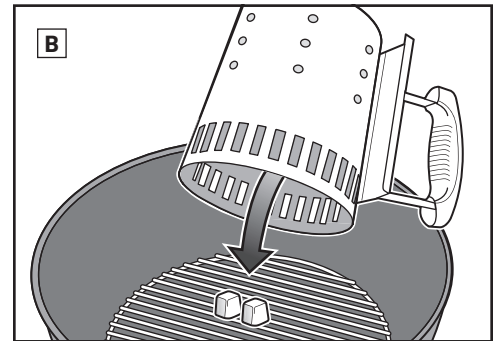

*Note: The lighter cubes used must be completely consumed and the charcoal ashed over before placing food on the grate. Do not cook before the fuel has a coating of ash.*

5. Once the charcoal is fully lit, continue to the following pages for instructions on how to arrange your charcoal and begin cooking according to your desired cooking method (Direct or Indirect method).

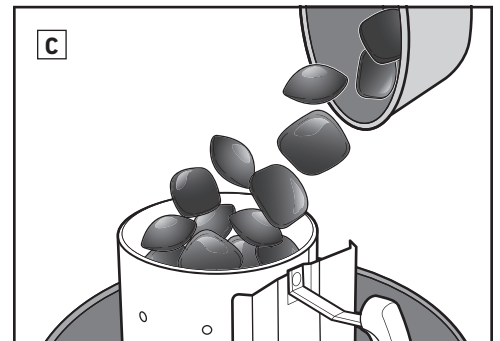

## Lighting the Charcoal Using Lighter Cubes

1. Build a pyramid of charcoal in the centre of the charcoal (bottom) grate and insert a couple of lighter cubes (sold separately) within the pyramid (E).
2. Using a long match or lighter, light the lighter cubes. The lighter cubes will then ignite the charcoal.
3. Wait for the charcoal to fully light. You can tell when the charcoal is fully lit when it is covered with a coating of white ash.

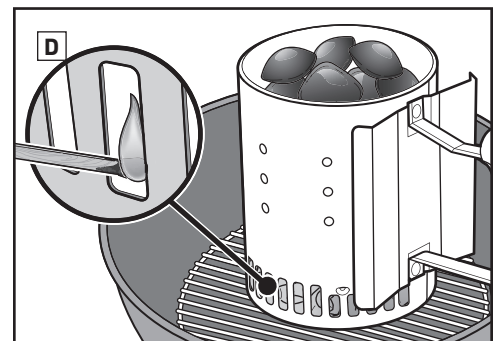

*Note: The lighter cubes used must be completely consumed and the charcoal ashed over before placing food on the grate. Do not cook before the fuel has a coating of ash.*

4. Once the charcoal is fully lit, continue to the following pages for instructions on how to arrange your charcoal and begin cooking according to your desired cooking method (Direct or Indirect method).

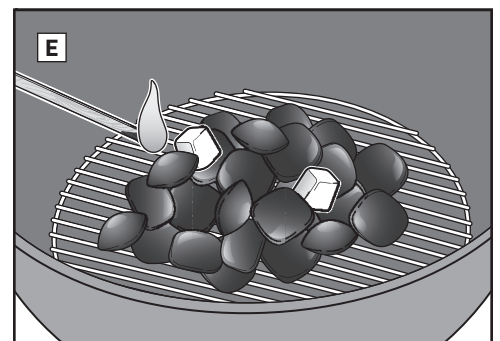



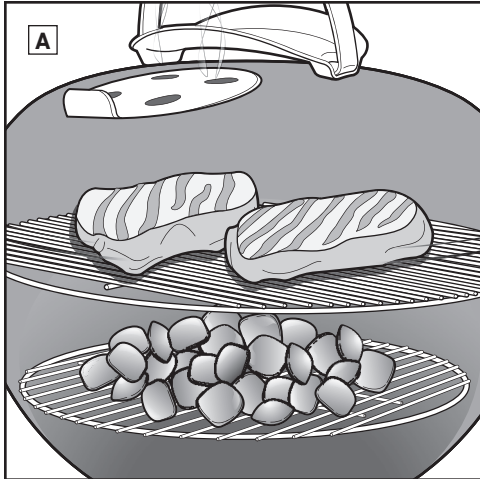

## Grilling With Direct Heat

Use the direct method for small, tender pieces of food that take less than 20 minutes to cook, such as:

- Hamburgers
- Steaks
- Chops
- Kabobs
- Boneless chicken pieces
- Fish fillets
- Shellfish
- Sliced vegetables

With direct heat, the fire is right below the food (A). It sears or browns the surfaces of the food, developing flavours, texture, and delicious caramelisation while it also cooks the food all the way to the centre.

A direct fire creates both radiant and conductive heat. Radiant heat from the charcoal quickly cooks the surface of the food closest to it. At the same time, the fire heats the cooking grate rods, which conducts heat directly to the surface of the food and creates those unmistakable and lovely grill marks.

## Arranging the Charcoal for Direct Heat

1. Always wear barbecue mitts or gloves conforming to EN 407, Contact Heat rating level 2 or greater, when using your charcoal barbecue.
2. After the charcoal is fully lit, spread them evenly across the charcoal grate with long tongs (B).
3. Replace the cooking grate.
4. Place the lid on the grill.
5. Open the lid damper (C).
6. Preheat the grate for approximately 10 to 15 minutes.
7. Once the cooking grate is preheated, using a stainless steel bristle grill brush, clean the cooking grate (D).

*Note: The grill, including the handle and damper/vent handles, will become hot. Make sure that you are wearing barbecue mitts or gloves to avoid burning your hands.*

8. Open the lid, and place your food on the grate.
9. Place the lid on the grill. Consult recipe for recommended cooking times.

*Note: Use a stainless steel bristle grill brush. Replace brush if any loose bristles are found on cooking grate or brush.*

### When finished cooking...

Close the lid damper and bowl vents to extinguish the charcoal.

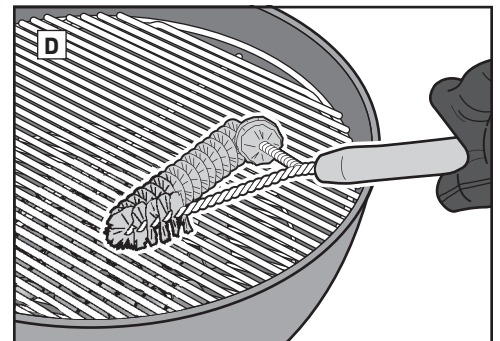
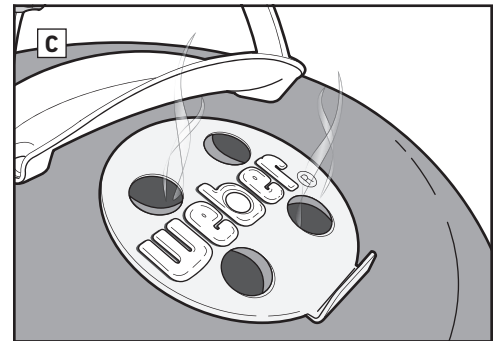
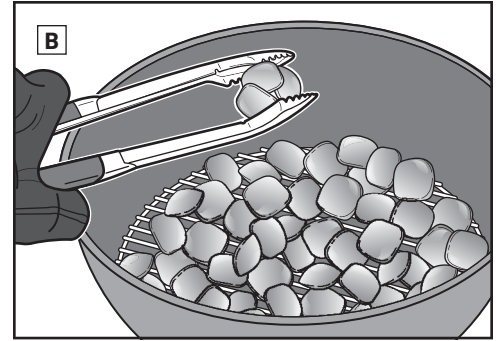

## Measuring & Adding Charcoal for Direct Heat

Grill Diameter	Charcoal Briquettes
47 cm	30 briquettes
57 cm	40 briquettes
67 cm	60 briquettes

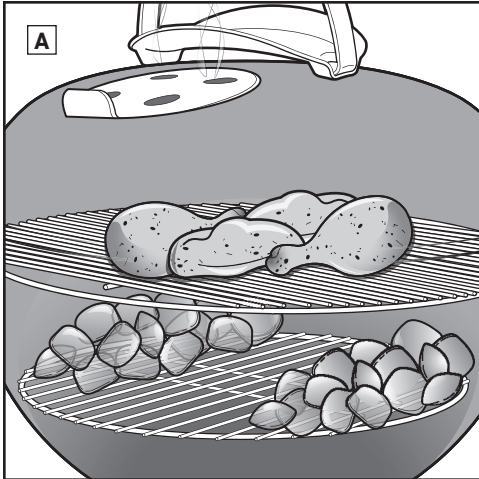

### Grilling With Indirect Heat

Use the indirect method for larger cuts of meat that require 20 minutes or more of grilling time, or for foods so delicate that direct exposure to the heat would dry them out or scorch them, such as:

- Joints
- Bone-in poultry pieces
- Whole fish
- Delicate fish fillets
- Ribs

Indirect heat can also be used for finishing thicker foods or bone-in cuts that have been seared or browned first over direct heat.

With indirect heat, the heat is on both sides of the grill, or off to one side of the grill. The food sits on the portion of the cooking grate without charcoal directly below it (A).

The radiant and conductive heat are still factors, but they are not as intense while indirect cooking. However, if the lid of the grill is closed, as it should be, there is another kind of heat generated: convection heat. Heat rises, reflects off the lid and inside surfaces of the grill, and circulates to slowly cook the food evenly on all sides.

Convection heat doesn't sear or brown the surface of the food the way radiant and conductive heat do. It cooks it more gently all the way to the centre, like the heat in an oven.

### Arranging the Charcoal for Indirect Heat

1. Put on barbecue mitts or gloves.  
*Note: The grill, including the handles, lid damper and bowl vents, will become hot. Make sure that you are wearing barbecue mitts or gloves to avoid burning your hands.*
2. After the charcoal is fully lit, with long tongs, arrange the charcoal so that they will be set on either side of the food (B). A drip pan may be placed between the charcoal to collect drippings.
3. Replace the cooking grate.
4. Place the lid on the grill.
5. Open the lid damper (C).
6. Preheat the grate for approximately 10 to 15 minutes.
7. Once the cooking grate is preheated, using a stainless steel bristle grill brush, clean the cooking grate (D).

*Note: Use a stainless steel bristle grill brush. Replace brush if any loose bristles are found on cooking grate or brush.*

8. Open the lid, and place your food on the grate.
9. Place the lid on the grill. Consult recipe for recommended cooking times.

*Note: When removing the grill lid during cooking, lift to the side, rather than straight up. Lifting straight up may create suction, drawing ashes up onto your food.*

#### When finished cooking...

Close the lid damper and bowl vents to extinguish the charcoal.

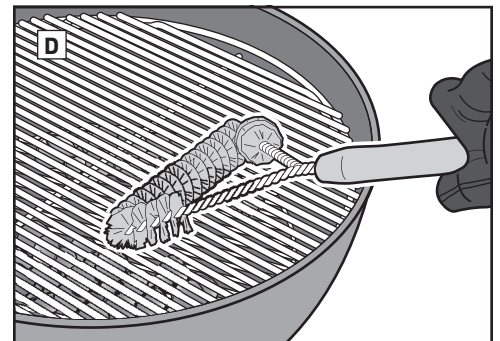
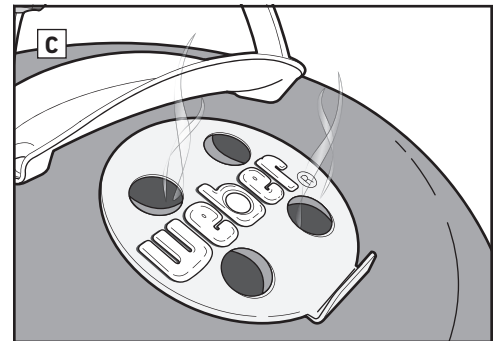
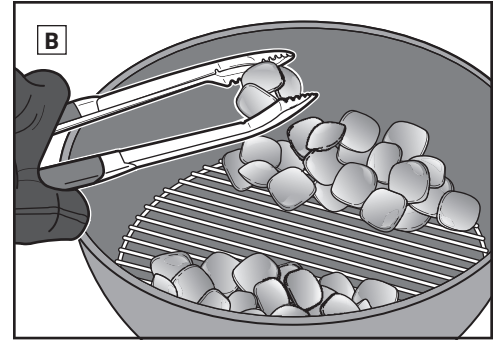

### Measuring & Adding Charcoal for Indirect Heat

Grill Diameter	Charcoal Briquettes	
	Briquettes for first hour (per side)	Briquettes to add for each additional hour (per side)
47 cm	15 briquettes	7 briquettes
57 cm	20 briquettes	7 briquettes
67 cm	30 briquettes	8 briquettes



### Wear Gloves

Always wear barbecue mitts or gloves conforming to EN 407, Contact Heat rating level 2 or greater, when using your charcoal barbecue. Vents, dampers, handles, and the bowl will all get hot during the grilling process, so be sure to keep your hands and forearms protected.

### Skip the Lighter Fluid

Avoid using lighter fluid, as it can impart a chemical taste to your food. Chimney starters (sold separately) and lighter cubes (sold separately) are much cleaner and much more effective ways of lighting charcoal.

### Preheat the Grill

Preheating your grill with the lid closed for 10 to 15 minutes prepares the cooking grate. With all of the charcoal glowing red, the temperature under the lid should reach 500°F. The heat loosens any bits and pieces of food hanging onto the grate, making it easy to brush them off with a stainless steel bristle grill brush. Preheating your grill gets the grate hot enough to sear or brown properly and also helps prevent food from sticking to the grate.

*Note: Use a stainless steel bristle grill brush. Replace brush if any loose bristles are found on cooking grate or brush.*

### Oil the Food, Not the Grate

Oil prevents food from sticking and also adds flavour and moisture. Lightly brushing or spraying the food with oil works better than brushing the grate.

### Keep the Air Flowing

A charcoal fire needs air. The lid should be closed as much as possible, but keep the lid damper and bowl vent open. Remove the ashes on the bottom of the grill regularly to prevent them from blocking the vents.

### Put a Lid on It

For four important reasons, the lid should be closed as much as possible.

1. Keeps the grate hot enough to sear or brown the food.
2. Speeds up the cooking time and prevents the food from drying out.
3. Traps the smokiness that develops when fat and juices vapourise in the grill.
4. Prevents flare-ups by limiting oxygen.

### Tame the Flame

Flare-ups happen, which is good because they sear or brown the surface of what you are grilling; however, too many flare-ups can burn your food. Keep the lid on as much as possible. This limits the amount of oxygen inside the grill, which will help extinguish any flare-ups. If the flames are getting out of control, move the food over indirect heat temporarily, until they die down.

### Watch the Time and Temperature

If you are grilling in a colder climate or in a higher altitude, the cooking times will be longer. If the wind is blowing hard, it will raise a charcoal grill's temperature, so always keep close to your grill and remember to keep the lid on as much as possible so that the heat does not escape.

### Frozen or Fresh

Whether you are grilling frozen or fresh food, follow the safety guidelines on the package and always cook it to the recommended internal temperature. Frozen food will take longer to grill and may need more fuel to be added depending on the type of food.

### Keeping it Clean

Follow a few basic maintenance instructions to keep your grill looking and grilling better for years to come!

- For proper air flow and better grilling, remove accumulated ashes and old charcoal from the bottom of the kettle and the ash catcher before use. Make sure that all of the charcoal is fully extinguished and the grill is cool before doing so.
- You may notice "paint-like" flakes on the inside of the lid. During use, grease and smoke vapours slowly oxidize into carbon and deposit on the inside of your lid. Brush the carbonised grease from the inside of the lid with a stainless steel bristle grill brush. To minimise further build-up, the inside of the lid can be wiped with a paper towel after cooking while the grill is still warm (not hot).
- If your grill is subject to a particularly harsh environment, you will want to clean the outside more often. Acid rain, chemicals, and salt water can cause surface rusting to appear. WEBER recommends wiping down the outside of your grill with warm soapy water. Follow up with a rinse and thorough drying.
- Do not use sharp objects or abrasive cleaners to clean the surfaces of your grill.





Cooking times for beef and lamb use the United States Department of Agriculture definition of medium doneness, unless otherwise noted. The cuts, thicknesses, weights and grilling times are meant to be guidelines. Factors such as altitude, wind and outside temperature can affect cooking times.

Visit [www.weber.com](http://www.weber.com) for recipes and grilling tips.

	Thickness/Weight	Approximate Total Grilling Time	
RED MEAT	<b>Steak:</b> New York strip, porterhouse, rib-eye, T-bone, and filet mignon (tenderloin)	2 cm thick	<b>4 to 6 minutes</b> direct high heat
		2.5 cm thick	<b>6 to 8 minutes</b> direct high heat
		5 cm thick	<b>14 to 18 minutes</b> brown 6 to 8 minutes direct high heat, and grill 8 to 10 minutes indirect high heat
	<b>Flank Steak</b>	0.7 kg to 1 kg, 2 cm thick	<b>8 to 10 minutes</b> direct medium heat
	<b>Minced Beef Patty</b>	2 cm thick	<b>8 to 10 minutes</b> direct medium heat
	<b>Tenderloin</b>	1.4 to 1.8 kg	<b>45 to 60 minutes</b> 15 minutes direct medium heat, and grill 30 to 45 minutes indirect medium heat
PORK	<b>Bratwurst: fresh</b>	85 g link	<b>20 to 25 minutes</b> direct low heat
	<b>Chop:</b> boneless or bone-in	2 cm thick	<b>6 to 8 minutes</b> direct high heat
		3 to 4 cm thick	<b>10 to 12 minutes</b> brown 6 minutes direct high heat, and grill 4 to 6 minutes indirect high heat
	<b>Ribs:</b> baby back, spareribs	1.4 to 1.8 kg	<b>1½ to 2 hours</b> indirect medium heat
	<b>Ribs:</b> country-style, bone-in	1.4 to 1.8 kg	<b>1½ to 2 hours</b> indirect medium heat
	<b>Tenderloin</b>	0.5 kg	<b>30 minutes</b> brown 5 minutes direct high heat, and grill 25 minutes indirect medium heat
POULTRY	<b>Chicken Breast:</b> boneless, skinless	170 to 227 g	<b>8 to 12 minutes</b> direct medium heat
	<b>Chicken Thigh:</b> boneless, skinless	113 g	<b>8 to 10 minutes</b> direct medium heat
	<b>Chicken Pieces:</b> bone-in, assorted	85 to 170 g	<b>36 to 40 minutes</b> 6 to 10 minutes direct low heat, 30 minutes indirect medium heat
	<b>Chicken:</b> whole	1.8 to 2.25 kg	<b>1 to 1¼ hours</b> indirect medium heat
	<b>Cornish Game Hen</b>	0.7 to 0.9 kg	<b>60 to 70 minutes</b> indirect medium heat
	<b>Turkey:</b> whole, unstuffed	4.5 to 5.5 kg	<b>2 to 2½ hours</b> indirect medium heat
SEAFOOD	<b>Fish, Fillet, or Steak:</b> halibut, red snapper, salmon, sea bass, swordfish, tuna	0.6 to 1.25 cm thick	<b>3 to 5 minutes</b> direct medium heat
		2.5 to 3 cm thick	<b>10 to 12 minutes</b> direct medium heat
	<b>Fish:</b> whole	0.5 kg	<b>15 to 20 minutes</b> indirect medium heat
		1.4 kg	<b>30 to 45 minutes</b> indirect medium heat
	<b>Shrimp</b>	14 g	<b>2 to 4 minutes</b> direct high heat
VEGETABLES	<b>Asparagus</b>	1.25 cm diameter	<b>6 to 8 minutes</b> direct medium heat
	<b>Maize</b>	in husk	<b>25 to 30 minutes</b> direct medium heat
		husked	<b>10 to 15 minutes</b> direct medium heat
	<b>Mushroom</b>	shiitake or button	<b>8 to 10 minutes</b> direct medium heat
		portobello	<b>10 to 15 minutes</b> direct medium heat
	<b>Onion</b>	halved	<b>35 to 40 minutes</b> indirect medium heat
		1.25 cm slices	<b>8 to 12 minutes</b> direct medium heat
	<b>Potato</b>	whole	<b>45 to 60 minutes</b> indirect medium heat
1.25 cm slices		<b>9 to 11 minutes</b> parboil 3 minutes, and grill 6 to 8 minutes direct medium heat	

Make sure food fits on the grill with the lid down, leaving approximately 2.5 cm of clearance between the food and lid.

## Cooking Tips

- Grill steaks, fish fillets, boneless chicken pieces, and vegetables using the direct method for the time given on the chart (or to the desired doneness) turning food once, halfway through grilling time.
- Grill roasts, whole poultry, bone-in poultry pieces, whole fish, and thicker cuts using the indirect method for the time given on the chart (or until an instant-read thermometer registers the desired internal temperature).
- Before carving, let roasts, larger joints of meat, and thick chops and steaks rest for 5 to 10 minutes after cooking. The internal temperature of the meat will rise 5 to 10 degrees during this time.
- For additional smoke flavour, consider adding hardwood chips or chunks (soaked in water for at least 30 minutes and drained) or moistened fresh herbs such as rosemary, thyme, or bay leaves. Place the wet wood or herbs directly on the coals just before you begin cooking.
- Thaw food before grilling. Otherwise, allow for a longer cooking time if cooking frozen food.

## Food Safety Tips

- Do not defrost meat, fish, or poultry at room temperature. Defrost in the refrigerator.
- Wash your hands thoroughly with hot, soapy water before starting any meal preparation and after handling fresh meat, fish, and poultry.
- Never place cooked food on the same plate raw food was on.
- Wash all plates and cooking utensils that have come into contact with raw meats or fish with hot, soapy water and rinse.



Weber-Stephen PRODUCTS LLC  
[www.weber.com](http://www.weber.com)